



Design Traffic Light of HCSR04 Sensor Fuzzy Logic Method Based on Arduino Mega 2560

Muhammad Dermawan, Selamat Meliala*

Departement of Electrical Engineering, Faculty of Engineering, Universitas Malikussaleh, Aceh, Indonesia

*Corresponding author E-mail: selamat.meliala@unimal.ac.id

Manuscript received 19 July 2022; revised 1 Sept 2022; accepted 15 Sept 2022. Date of publication 4 Nov 2022

Abstract

Modern technology is developing quite fast. Manufacturing, consumer electronics, and traffic management are just a few everyday tasks made more accessible by various technologies. Regular traffic signals work according to a set time or hour according to one road condition. Therefore, it is essential to time traffic signals at intersections so drivers must wait for the shortest time. In this study, we explore the feasibility of modeling a control system using the fuzzy Mamdani algorithm so that the timing of traffic lights at highway intersections can be adjusted in real-time. Each element, such as the number of cars, motorbikes, and road width, plays a role in determining whether or not a traffic light is activated. It is possible to get a red light that changes adaptively in response to road conditions by conducting tests with varying parameter settings. Based on the results of testing the system as a whole, it can be determined that traffic lights can prioritize the long green density first among the four lanes if the number of cars in one of the lanes is more, and those in the fewer lanes will take precedence over the more congested roads. That system testing is booming, according to design. Battery-free toy vehicles were deployed on each track for testing. The sensor will recognize the car as an object and interpret the data sent and received by the Arduino Mega processing system. The system will then analyze the density condition and display it on the LCD and sensor data, the length of the green traffic light, and the density condition.

Keywords: Traffic Light, Determination, Fuzzy Logic.

1. Introduction

Modern technology is developing quite fast. Manufacturing, consumer electronics, and traffic management are just a few everyday tasks made more accessible by various technologies. Regular traffic signals work according to a set time or hour according to one road condition. In all holding and running times with a fixed or consistent current time; for one case, the framework is acceptable and usable. The framework is pleasing and functional. Its main drawback is that when there are adjustments to road conditions, for example, during rush hours or vice versa, the traffic signal settings become ineffective. Traffic lights should have the option to change according to road conditions so that the trafficking framework is smoother. Fuzzy logic traffic light control is an alternative to Conventional Traffic Signal Control that can lay out a broader range of intersection traffic patterns. As a substitute for Proximity sensors that only indicate the presence of vehicles, traffic lights that operate fuzzy logic use sensors that count cars. This gives controllers the traffic density on the lanes and allows a better assessment of changing traffic patterns. Because the traffic distribution fluctuates, the fuzzy controller can change the signal lights according to traffic conditions [1]. An extension of boolean logic, fuzzy logic, was created by an American scientist with an Iranian last name, Lotfi Asker Zadeh. In contrast to Boolean logic, which only recognizes black or white, this fuzzy logic contains grayscale and has a truth value in the form of an interval. It also acknowledges the concept of ambiguity [2]. The Mamdani method is a fuzzy logic technique that operates according to predetermined linguistic rules. Particularly in Indonesia, the number of customers using public transportation is increasing. Even though the number of vehicles is rising, the number of roads remains the same, causing high traffic density and congestion. Things get even more chaotic when one path meets another, called convergence. It is located with the necessary control unit, called a traffic light. According to RI Law no. 14 of 1992, traffic is the movement of cars, people, and living things in traffic areas. This definition has fundamental expectations for developing vehicles, people, and other goods, such as roads and supporting aids. Meanwhile, traffic jams or even traffic jams caused by the number of cars exceeding the speed limit indicate the importance of congestion [3]. Based on the above problems, a traffic light control system will be developed based on the number of detected vehicle densities. The system will use the hcsr04 sensor and a fuzzy logic system to determine the duration of traffic lights in real-time when one of the lanes is filled, at which point this lane was originally green. In the future, it is hoped that by using this device as an intersection traffic signal, it will be possible to eliminate uneven traffic volumes and simultaneously change traffic conditions.



2. Literature Review

2.1. Traffic lights

According to law no. 22/2009 on road traffic and transport, traffic lights are called "traffic signaling devices". These are placed at intersections, pedestrian crossings (zebra crossings), and other places where traffic flows. [4] These lights signal when cars must stop and start sequentially coming from different directions. The goal of traffic management at an intersection is to coordinate the travel of each group of cars so that they can go in opposite directions and not obstruct oncoming traffic.[5]



Fig 1. Traffic Light

Figure 1 Traffic Lights Different traffic signal controllers are available in various forms. These factors depend heavily on the context and current characteristics of the intersection, including the volume, shape of the intersection, etc. Various types of traffic light controllers are available for savings, depending on their purpose. Since the cycle length and phase are set at predetermined intervals, it is the most affordable and direct method of signal setting. This type is not as effective as the real type because it doesn't account for traffic fluctuations. Therefore, it is preferable to use multiple settings (multi-settings) in various contexts in one day for control reasons. This time frame often refers to the morning, afternoon, and evening rush hours. Cycle duration and phase length are continuously adjusted by a system-controlled light signaling system to accommodate incoming traffic flow. Also set maximum and lowest green time values. At each intersection, indicators are placed to detect approaching cars. The information is stored in memory and processed to provide a second time value above the minimum green junction time value. As a result, this control system is highly responsive to the environment and is used very successfully to reduce delays at intersections. Traffic operations are divided into two categories, partial operations, and full operations. Semi-powered signal timing is made at intersections when main roads have more traffic than minor roads. The lanes have sensors placed to detect cars coming from them, and these sensors are programmed to always signal a longer green light on these routes. Real-time signaling is full power operation used at intersections where the distribution fluctuates and varies but the traffic flow is generally the same at each branch of the intersection. At each intersection, indicators are placed. Maximum and minimum green times are set for each junction branch at this fully powered junction. Cycle times may vary depending on the volume of traffic that will enter the intersection during the day. For fixed-time traffic light settings, it is necessary to define a cycle period that can prevent excessive delays in large traffic flows. This situation is not a problem for traffic-based traffic system setups. Types of control at traffic lights [6]:

- a. Fixed time setting, this control does not change, Play time for each lane turning red is fixed.
- b. Dynamic Control: This control system prioritizes solid lanes and does not turn green at all if there are no vehicles in line.
- c. Coordinated control, this control system coordinates between adjacent traffic lights and avoids long queues between two traffic lights.
- d. In several places for troubleshooting, the flow of vehicles is heavy and there are no crossings.

2.2. Arduino Mega 2560

Arduino is an open-source single-board microcontroller developed from the Wiring Platform and made to facilitate the use of electronics, namely Atmel AVR-type microcontroller processors, in various applications. IC).[7] The microcontroller itself is a chip or IC (Integrated Circuit) that can be programmed by a computer. The purpose of embedding a program on a microcontroller is so that the electronic circuit can read the input, process the input, and produce the desired output. Thus, the microcontroller acts as a brain that controls the process of plugging in and out of electronic circuits Write. The minimum standard for this template, please follow this guide must exist for a manuscript.



Fig 2. Arduino mega 2560.

Table 1. Arduino Mega 2560 Specifications

Microcontroller	ATMega 2560
Operating Voltage	5 V
Input Voltage (recommended)	7-12 V
Input Voltage (limit)	6-20 V
Pins I/O Digital	54 (of which 14 provide PWM outputs)
Analog Input Pins	16
DC Current Per I/O Pin	40 mA
DC Current For Pin 3.3 V	50 mA
Flash Memory	256 kb of which 8 kb is used by the bootloader
SRAM	8 kb
EEPROM	4 kb
Speed Clock	16 MHz

The board has multiple I/O pins, including 4 UART (hardware serial ports) ports, 16 analog input pins, and a total of 54 digital I/O pins, 15 of which are PWM pins. A 16 Mhz oscillator, USB, DC power connection, ICSP header, and reset button are all features of the Megaport Arduino 2560. This board has everything a microcontroller needs, so it is very comprehensive [8].

2.3. Fuzzy Logic

Fuzzy is the English word for unclear or fuzzy. Therefore, fuzzy logic is reasoning that is fuzzy or has a sense of urgency. In assertive logic, which makes sense, there are only two possible outcomes true or false, or 0 or 1. Fuzzy logic, on the other hand, understands the difference between right and wrong. With fuzzy logic, the truth can be expressed in degrees of truth that range from 0 to 1. For example, in common usage, adults are those who are 17 years or older. Anyone who is 17 years minus one day is considered a minor in formal English. On the other hand, this individual can be characterized as being almost mature in fuzzy logic. pay attention to the following picture

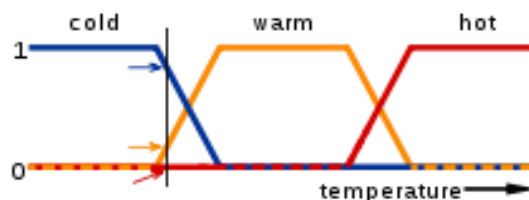
**Fig 3.** Temperature Differences In Fuzzy Logic

In its design, fuzzy logic has three stages fuzzification, rule evaluation, and defuzzification. Fuzzification is the first step in transforming statement language (statement value) into fuzzy input sentences. The evaluation rules are then fuzzy rules which contain IF-THEN rules, each rule has its own value to be processed by defuzzification. Finally, defuzzification is the process of converting fuzzy output sentences into the proper language used for system output. Below is a picture of the process of processing fuzzy logic.[9].

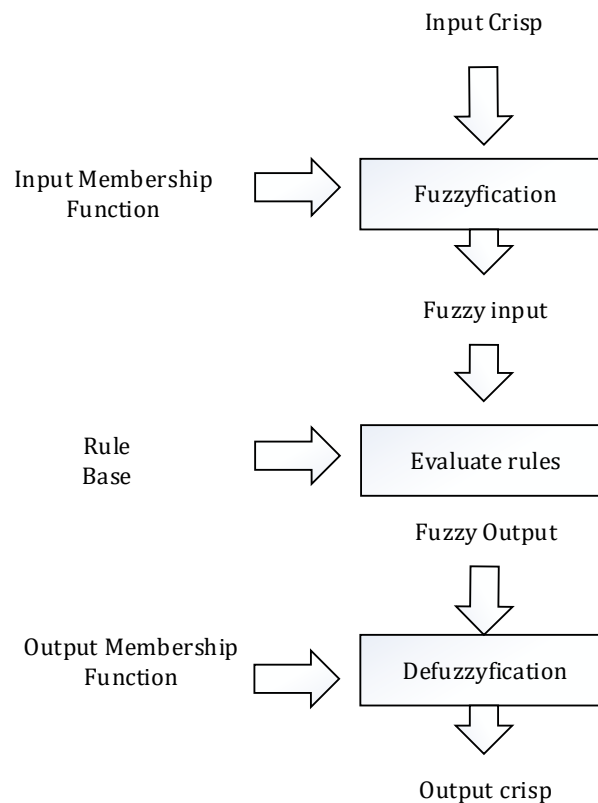

Fig 4. Fuzzy Logic Block Diagram

2.4. HCSR04 Sensor

Sensors called ultrasonic sensors to work by converting electrical values into physical quantities (sound) and vice versa. The operation of this sensor is based on the idea of sound waves reflecting off a surface to interpret the presence of objects with certain frequencies and distances. Because it uses sound waves or is called ultrasonic, this sensor is known as an ultrasonic sensor (ultrasonic sound). Ultrasonic waves are sound waves with a fairly high frequency of 20,000 Hz. The human ear is unable to hear ultrasonic sounds. Solids, liquids, and gases can all pass through ultrasonic waves. Almost identical to the reflection of ultrasonic sound on a liquid surface is the reflectivity of ultrasonic sound on a solid surface. However, foam and cloth will absorb ultrasonic waves.[10].

- a. HC-SR04 Ultrasonic Sensor Features The operating voltage for a single source is 5.0 V.
- b. 2 A current of 15 mA is used.
- c. 40KHz is the operating frequency.
- d. Detection distance of at least 0.02 meters (2 cm).
- e. The maximum detection range is 4 m.
- f. The bounce angle of the wave meter is 15 degrees.
- g. TTL level pulse with a minimum ignition timing of 10 microseconds.
- h. TTL pulse detection rate with duration related to the distance detection

3. Methods

The module designed in this research is in the form of a fuzzy algorithm traffic light tool using the hcsr04 ultrasonic sensor which functions as a traffic density detector then the incoming density data becomes an Arduino mega 2560 interrupt after the microcontroller receives data from one of the hcsr04 paths that detect density then the data is processed using a fuzzy algorithm to generate new data, namely the detected path will be automatically greened. prioritizes that way as the first search according to the algorithm built into the microcontroller when one of the paths is identified as dense among the four paths. spacing.

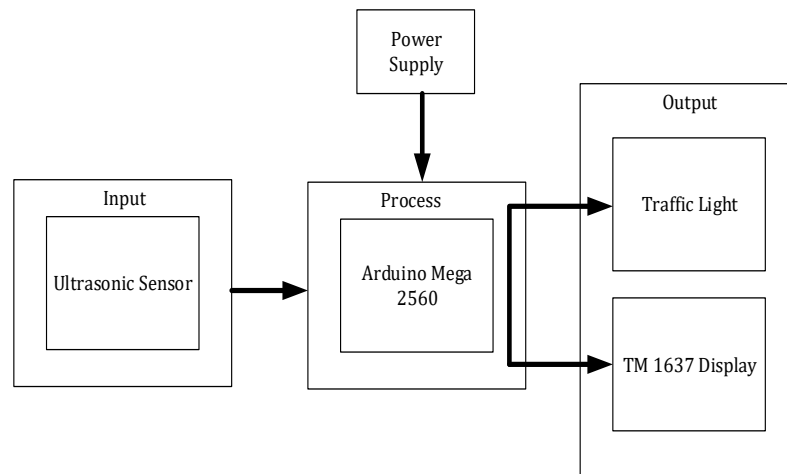

Fig 5. Diagrams Design Block

3.1. Fuzzy Logic Test

The following is an explanation of the testing stages:

- At each four-lane traffic light, indicate the status of the red, green, and yellow lanes.
- Ultrasonic sensor that counts the number of cars in each lane as an input variable; if the lane is full of cars, the ultrasonic sensor gives out a high or suit indication.
- The value of the ultrasonic sensor is given by a fuzzy algorithm, which then repeats continuously depending on the state of the ultrasonic sensor to change the vehicle density value for each lane based on each lane
- Waiting time and ultrasound should be the input variables for the Mandani technique.
- Using variable values as determining conditions for each variable member
- Fuzzy selects and fuzzified values based on input variables such as ultrasonic sensors based on predetermined values.
- The value of each traffic light situation can be calculated using Mandani fuzzy calculations.

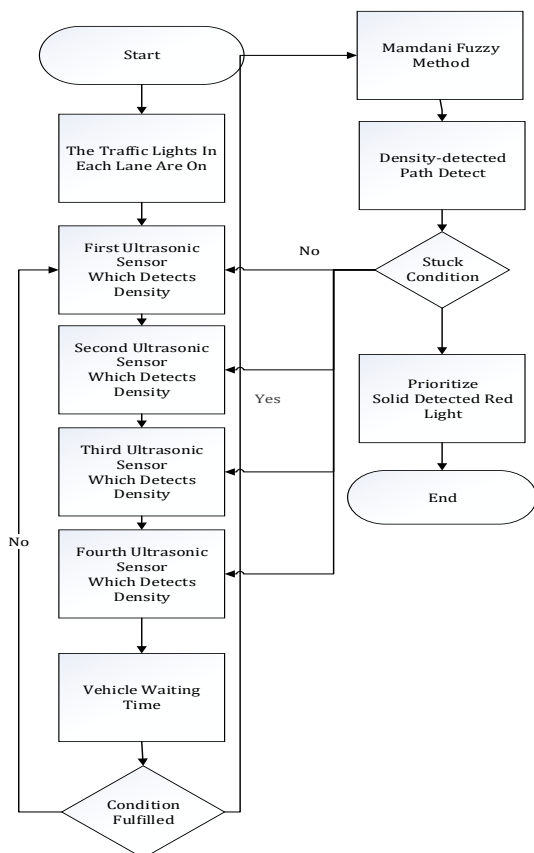

Fig 6. Fuzzy Logic Flowchart

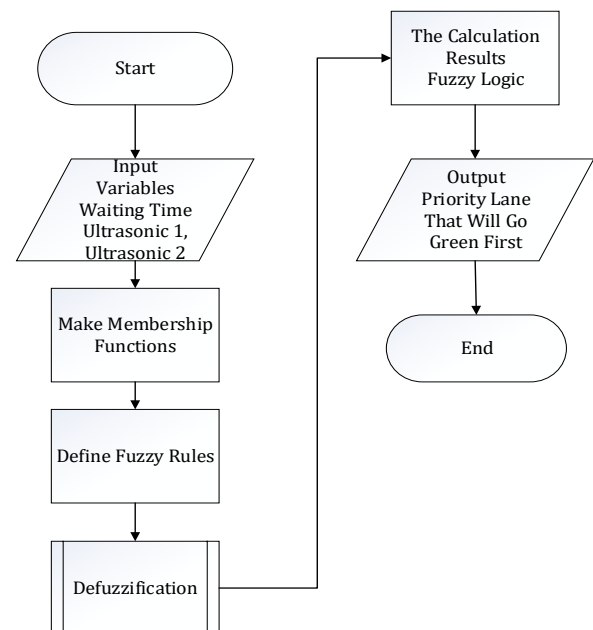

Fig 7. Mamdani Method Flowchart

The first step is the fuzzification rules, which include identifying a subset of the HCSR variables and modifying the function based on Figure 8 and the input values. Utilization of Fuzzy Logic Toolbox Fuzzy Inference System (FIS) The author uses fuzzy inference techniques to determine the number of seconds of green light at each intersection. Utilizing the Mamdani type with the Fuzzy Logic Toolbox in the Matlab R2009a application. The fuzzy inference system approach requires at least four phases when using fuzzy logic control techniques.

In particular, the FIS Editor, defines the input and output variables, the membership function editor, which defines the potential level of linguistic variables, the rule editor, defines the antecedent and consequence rules, and the rule viewer defines the defuzzification.

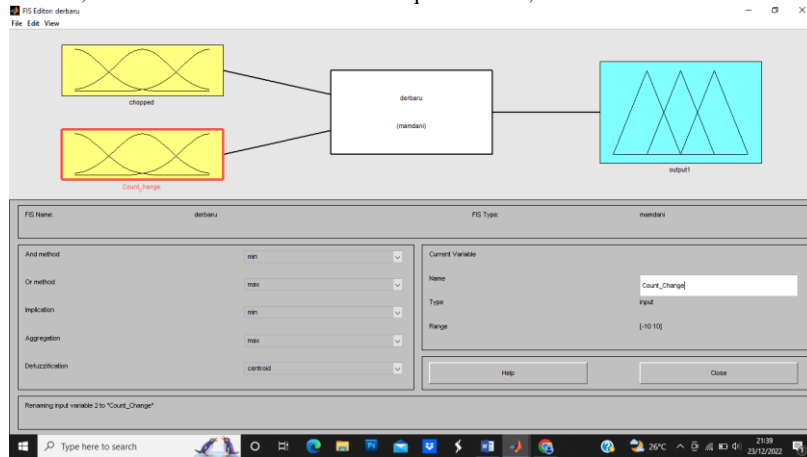

Fig 8. Fuzzy Inference System Traffic light

1. Input Variables

There are 2 input variables and 1 output in Mamdani Fuzzy Logic in FIS Matlab where the input variable counts and changes in the count. In the count variable, there are 5 input models where the duration of the queue length is very little, a little, normal, a lot, and very a lot.

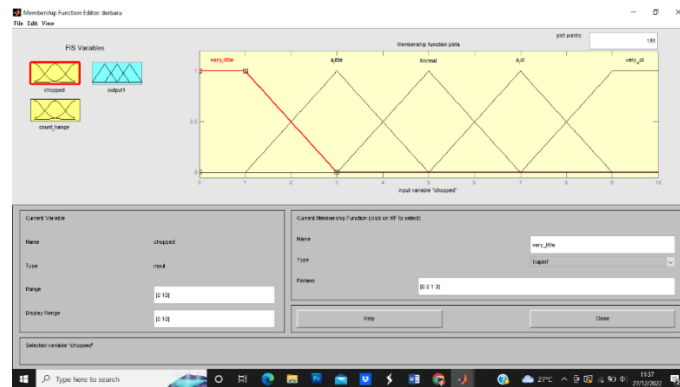

Fig 9. Input 1 Fuzzy Inference System Traffic light

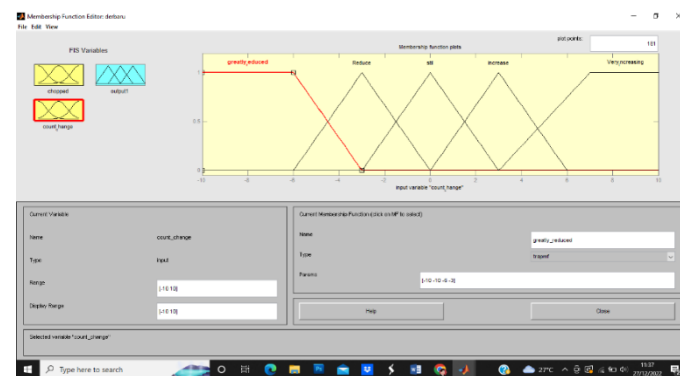

Fig 10. Input 2 Membership Function Matlab Counts

2. Output Variable

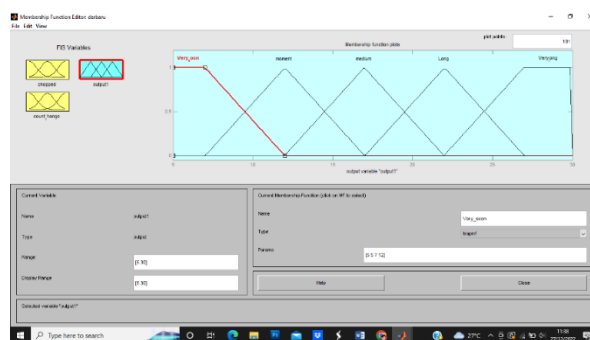

Fig 11. Membership Function Output Matlab

The next step in the fuzzification procedure is to develop a rule editor to define input (antecedent) and output (consequent) causal (consequent) relationships. In this approach, the 25 linguistic input variables consist of the two most recent linguistic input variables. Given the 25 linguistic input variables, a maximum of 120 rules can be created that can affect the value of the linguistic output. However, to simplify the system, only 25 rules are made in this application. A connection system that uses an implicit protocol to indicate the relationship between inputs (and). Figure 11 depicts the Rule Editor for a traffic light system with FIS.

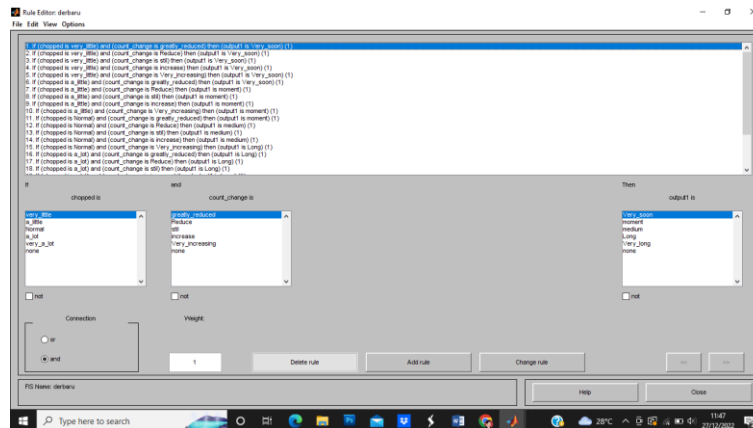

Fig 12. Rule Editor in Traffic Light Systems with Fuzzy Logic Control

The aggregation process is carried out based on the possibility of sensor readings on each side of the deviation. Where the sensor readings are the antecedents of each path and the consequence is the resulting time variable for the length of time the light turns green. There are 25 rules used. For the aggregation process see the following rules.

Below is an inference of 25 combinations of instructions that are applied to fuzzy for ultrasonic sensors :

1. If (chopped is very_little) and (count_change is greatly_reduced) then (output1 is Very_soon) (1)
2. If (chopped is very_little) and (count_change is Reduce) then (output1 is Very_soon) (1)
3. If (chopped is very_little) and (count_change is still) then (output1 is Very_soon) (1)
4. If (chopped is very_little) and (count_change is increase) then (output1 is Very_soon) (1)
5. If (chopped is very_little) and (count_change is Very_increasing) then (output1 is Very_soon) (1)
6. If (chopped is a_little) and (count_change is greatly_reduced) then (output1 is Very_soon) (1)
7. If (chopped is a_little) and (count_change is Reduce) then (output1 is a moment) (1)
8. If (chopped is a_little) and (count_change is still) then (output1 is a moment) (1)
9. If (chopped is a_little) and (count_change is increasing) then (output1 is a moment) (1)
10. If (chopped is a_little) and (count_change is Very_increasing) then (output1 is moment) (1)
11. If (chopped is Normal) and (count_change is greatly_reduced) then (output1 is a moment) (1)
12. If (chopped is Normal) and (count_change is Reduce) then (output1 is medium) (1)
13. If (chopped is Normal) and (count_change is still) then (output1 is medium) (1)
14. If (chopped is Normal) and (count_change is increasing) then (output1 is medium) (1)
15. If (chopped is Normal) and (count_change is Very_increasing) then (output1 is Long) (1)
16. If (chopped is a_lot) and (count_change is greatly_reduced) then (output1 is Long) (1)
17. If (chopped is a_lot) and (count_change is Reduce) then (output1 is Long) (1)
18. If (chopped is a_lot) and (count_change is still) then (output1 is Long) (1)
19. If (chopped is a_lot) and (count_change is increasing) then (output1 is Long) (1)
20. If (chopped is a_lot) and (count_change is Very_increasing) then (output1 is Very_long) (1)
21. If (chopped is very_a_lot) and (count_change is greatly_reduced) then (output1 is Very_long) (1)
22. If (chopped is very_a_lot) and (count_change is Reduce) then (output1 is Very_long) (1)
23. If (chopped is very_a_lot) and (count_change is still) then (output1 is Very_long) (1)
24. If (chopped is very_a_lot) and (count_change is increase) then (output1 is Very_long) (1)
25. If (chopped is very_a_lot) and (count_change is Very_increasing) then (output1 is Very_long) (1)

Figure 12 illustrates the relationship between two input variables as antecedents implied by the conjunction "and" and the output as a result. This combination of inputs and outputs will produce defuzzification whose value is determined by the firm's value (crisp). To observe the defuzzification, the rules viewer is shown as illustrated in Figure 13 below.

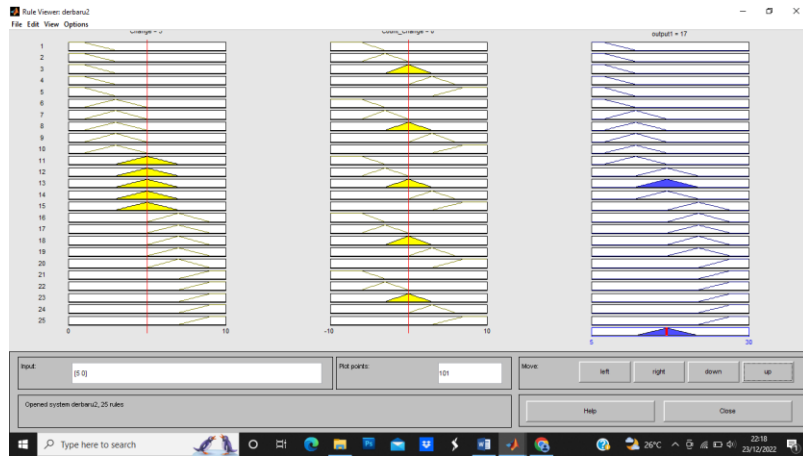

Fig 13. Rule Viewer for System Defuzzification

In the defuzzification procedure using the rule viewer shown in Figure 13 the strict value of each input variable can be adjusted by writing the linguistic input value in the GUI input or by moving the red line on each variable. The indicator light will then display the exact time value in seconds.

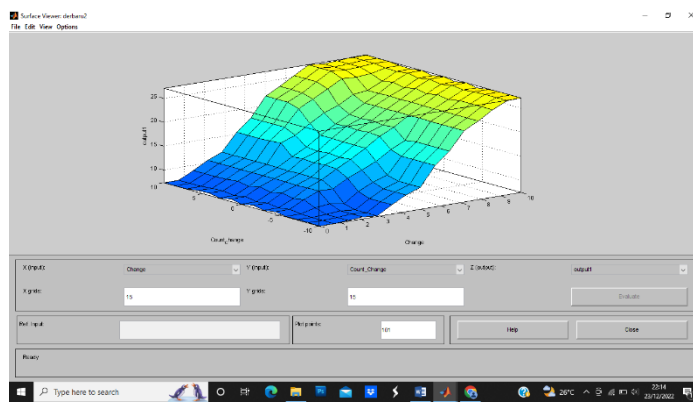

Fig 14. Surface Viewer

Figure 14 shows that the duration of the green light is emphasized by the total density of each traffic lane. This kind of division is more efficient when compared to a conventional system where the green light is always the same and does not depend on the amount of accumulation on other roads and vice versa.

3.2. Implementation of Ultrasonic Sensor Detection 1 and 2

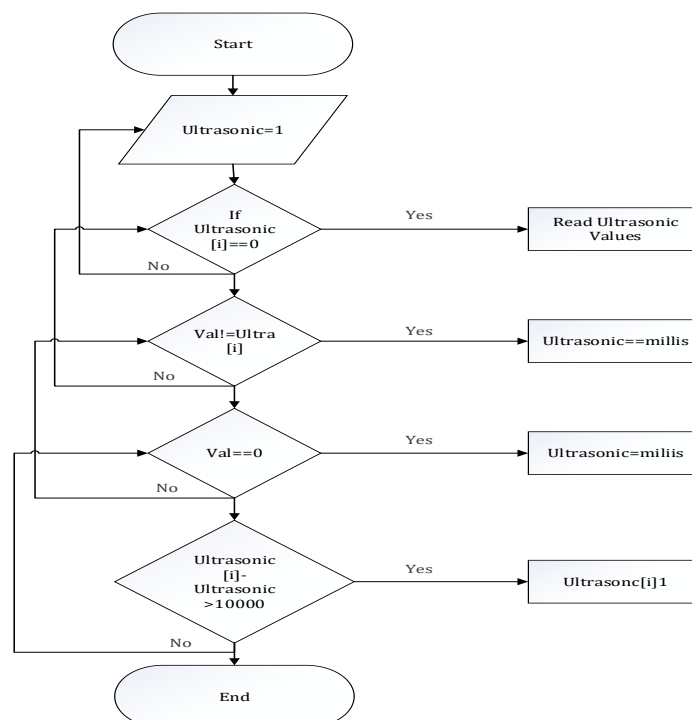

Fig 15. Implementation of Ultrasonic Sensor Detection 1 and 2

Figure 15 above shows that the first and second ultrasonic sensors have been used to identify objects on the route when the red light is on. After the green light turns red, the first ultrasonic sensor activates, identifies a vehicle that has stopped directly in front of the sensor, and enters the information as one of the fuzzy inputs. When the light turns red, Ultrasonic Sensor 2 also operates and detects the vehicle directly in front of the sensor, generating fuzzy rule calculations. Each sensor has a significant impact on how the lights are.

4. Results and Discussion

The prototype has a size of 60 cm x 60 cm with a track length of 50 cm x 50 cm; However, in its implementation, the prototype shape changed to a "box" or Junction 4 shape with a length of 50 cm x 60 cm for each track made of plywood with a thickness of 5 cm and four wooden blocks with a height of 6 cm. as a supporting leg as Figure 16.



Fig 16. Traffic Light Prototype

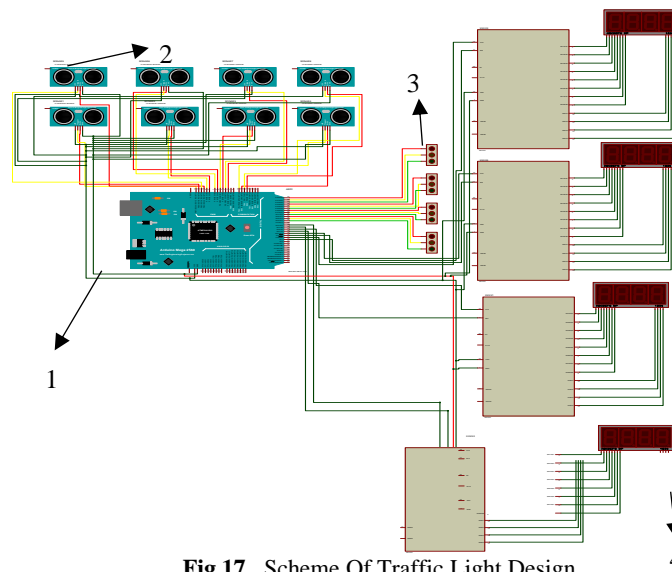

Fig 17. Scheme Of Traffic Light Design

Where:

1. Arduino Mega 2560 to design and manufacture this tool because it is easier to control and functions as a container for programs that can be placed so that algorithms can be embedded according to user needs and can be run
2. HCSR04 or ultrasonic is used to detect the density of vehicles on one of the lanes.
3. LEDs are used as red, yellow, and green traffic lights.
4. TM1367 is used as a seven-segment traffic light delay

4.1. Overall System Testing And Analysis

The purpose of this test is to assess whether the system in question can function properly according to a predetermined design. Following the system work process, system testing is carried out sequentially and thoroughly. To perform the test, unpowered toy vehicles are placed in each lane, the HC-SR04 sensor detects the vehicles, and the data is passed to the Arduino mega system for processing. After processing, Arduino Mega as a system will determine the density conditions and send data to the LCD to be displayed as a traffic light. The results of testing the entire system are shown in Figures 17, 18, 19, and 20 below.



Fig 17. Pathway 4 Prototype Testing



Fig 18. Pathway 3 Prototype Testing



Fig 19. Pathway 2 Prototype Testing



Fig 20. Pathway 1 Prototype Testing

In addition, the description is explained in Table 2, Table 3, Table 4, and Table 5.

Table 2. Prototype Testing on Line 4

Detected Path Number	Number of Cars	Prioritized Line	Works Status
Line 1	2	Comes Second	Good
Line 2	0	Comes Third	Good
Line 3	1	Comes Fourth	Good
Line 4	3	Comes First	Good

Based on the following table 2, it is obtained that the prioritized path is lane 4 where lane 4 is the lane that detects more density and the number of cars than the other lanes.

Table 3. Prototype Testing on Line 3

Detected Path Number	Number of Cars	Prioritized Line	Works Status
Line 1	2	Comes Second	Good
Line 2	0	Comes Fourth	Good
Line 3	3	Comes First	Good
Line 4	1	Comes Third	Good

Based on the following Table 3, it is obtained that the prioritized path is lane 3 where lane 3 is the path detected by the density and the number of cars that are more than the other lanes

Table 4. Prototype Testing on Line 2

Detected Path Number	Number of Cars	Prioritized Line	Works Status
Line 1	0	Comes Fourth	Good
Line 2	3	Comes First	Good
Line 3	2	Comes Second	Good
Line 4	1	Comes Third	Good

Based on the following Table 4, it is obtained that the prioritized path is lane 3 where lane 2 is the lane that detects more density and the number of cars than the other lanes

Table 5. Prototype Testing on Line 1

Detected Path Number	Number of Cars	Prioritized Line	Works Status
Line 1	3	Comes First	Good
Line 2	2	Comes Second	Good
Line 3	1	Comes Third	Good
Line 4	0	Comes Fourth	Good

Based on the following Table 5, it is obtained that the prioritized path is lane 3 where lane 3 is the path detected by the density and the number of cars that are more than the other lanes

5. Conclusion

Based on the result of prototype testing, the design hashing runs as expected Fuzzy logic control settings are more effective than time-based settings for traffic signals. Because the traffic light settings based on Fuzzy Logic Control assess the amount of traffic density, they can prioritize the lane with the highest vehicle density.

Traffic light settings using fuzzy logic control pay attention to the interests of other traffic lane users by setting a minimum and maximum completion time for the fuzzy logic work system. And implementation of Fuzzy Logic Control on Arduino can be achieved in two ways: by directing the rule editor to the Arduino program, or by using a lookup table technique with more comprehensive rule viewer data.

References

- [1] K. K. Tan, M. Khalid, and R. Yusof, "Intelligent traffic lights control by fuzzy logic," *Malaysian J. Comput. Sci.*, vol. 9, no. 2, pp. 29–35, 1996.
- [2] R. Megasari and K. Novianingsih, "Optimisasi Delay Lampu Hijau Dengan Logika Fuzzy Metode," *Eureka Matika*, vol. 5, no. 2, 2017.
- [3] M. I. Herdiansyah *et al.*, "Pengaturan Lampu Lalu Lintas Menggunakan Pendekatan Sistem Pakar," *J. Ilm. Matrik*, vol.18,no.3,pp.241–250,2016.[Online].Available: <http://journal.binadarma.ac.id/index.php/jurnalmatrik/article/view/414>.
- [4] A. Suhartono, "Lampu Lalulintas Adaptif untuk Simpangan Padat Menggunakan Simple Additive Weight," vol. 04, no. 01, pp. 7–15, 2022, doi: 10.52985/insyst.v4i1.222.
- [5] M. S. Khatami, R. A. Rajagede, and R. Rahmadi, "Sebuah Tinjauan Pustaka dari Studi-Studi Terkini Tentang Sistem Manajemen Lampu Lalu Lintas Adaptif," *Automata*, vol. 2, no. 1, pp. 1–6, 2021.
- [6] A. Adria, "Perancangan Pengontrolan Traffic Light Otomatis," *Peranc. Pengontrolan Traffic Light Otomatis*, vol. 9, no. 3, pp. 126–131, 2011.
- [7] E. A. Nugroho, "Sistem Pengendali Lampu Lalulintas Berbasis Logika Fuzzy," *J. SIMETRIS*, vol. 8, no. 1, pp. 75–84, 2017.
- [8] Windarto and M. Haekal, "Aplikasi Pengatur Lampu Lalu Lintas Berbasis Arduino Mega 2560 Menggunakan Light Dependent Resistor (LDR) dan Laser," *Arsitron*, vol. 3, no. 2, pp. 98–107, 2012.
- [9] Irna Tri Yuniahastuti, Yussi Anggraini. Rio Alfa Risky, "Pengembangan Trainner Traffic LightMenggunakan Arduino Uno Pada MahasiswaTeknik Elektro Universitas PGRI Madiun," *Fakt. J. Ilm. Kependidikan Vol. 6 No. 3 Nop. 2019, hal 177-182*, vol. 3, no. 3, pp. 177–182, 2019.
- [10] I. Puspita, E. Suryani, and A. M. Abadi, "Aplikasi fuzzy logic controller pada pengontrolan lampu lalu lintas di jalan Abu Bakar Ali, Yogyakarta," *Semin. Mat. dan Pendidik. Mat. UNY 2017*, no. 0, pp. 93–98, 2012.
- [11] A. A. Nugroho, N. M. Muhyiddin, R. N. Wardhani, I. H. Kresno, J. T. Mesin, and P. N. Jakarta, "Prototipe Smart Traffic Light System," pp. 596–605, 2018.
- [12] H. Himawan, "Prototipe Lampu Lalu Lintas Adaptif Berbasis Multi Agent Manggunakan Logika Fuzzy Yang Tertanam Pada Microcontroller," *J. Teknol. Inf.*, vol. 12, pp. 84–102, 2016, [Online]. Available: <http://research.pps.dinus.ac.id>.
- [13] A. M. Priyatno and R. Oktavianus, "Perancangan Perangkat Lunak Simulasi Lampu Lalu Lintas Menggunakan Metode Fuzzy Tsukamoto," *J. TISI*, vol. 1, no. 372, pp. 89–101, 2017, [Online]. Available: <http://sisfotenika.stmikpontianak.ac.id/index.php/TISI/article/view/924>.
- [14] S. Setianto, "Pengaturan Lampu Lalulintas Berbasis Fuzzy Logic," *J. Ilmu dan Inov. Fis.*, vol. 1, no. 2, pp. 16–20, 2017, doi: 10.24198/jiif.v1i02.12795.
- [15] S. Meliala, "Analisis Tegangan Keluaran DC Step-Up Cuk Konverter Menggunakan Fuzzy Logic Kontroler," *J. Electr. Technol.*, vol. 1, no. 1, pp. 17–24, 2016.
- [16] R. A. T. Aufik *et al.*, "Rancang Bangun Simulator Kendali Lampu Lalu Lintas Dengan Logika Fuzzy," *Seminar*, vol. 2008, no. RAHMAT TAUFIK, pp. 1–26, 2008.
- [17] S. Sabaar and S. S, "Rancang Bangun Kontrol Lampu Lalu Lintas Simpang Tiga Berbasis Arduino," *J. Informatics Electron. Eng.*, vol. 2, no. 1, pp. 10–14, 2022.
- [18] D. Nusyirwan, "'Fun Book' Rak Buku Otomatis Berbasis Arduino Dan Bluetooth Pada Perpustakaan Untuk Meningkatkan Kualitas Siswa," *J. Ilm. Pendidik. Tek. dan Kejuru.*, vol. 12, no. 2, p. 94, 2019, doi: 10.20961/jiptek.v12i2.31140.
- [19] D. Suhardi, "PROTOTYPE CONTROLLER LAMPU PENERANGAN LED (LIGHT EMITTING DIODE) INDEPENDENT BERTENAGA SURYA Prototype Lamp Lighting Controller LED (Light Emitting Diode) Independent Solar Jika kita perhatikan cadangan energi dari bahan minyak bumi di Indonesia diper," *Jurna GAMMA*, vol. 10, no. September, pp. 116–122, 2014.
- [20] A. D. Limantara, Y. C. S. Purnomo, and S. W. Mudjanarko, "Pemodelan Sistem Pelacakan Lot Parkir Kosong Berbasis Sensor Ultrasonic Dan Internet of Things (Iot) Pada Lahan Parkir Diluar Jalan," *Semin. Nas. Sains dan Teknol.*, vol. 1, no. 2, pp. 1–10, 2017, [Online]. Available: jurnal.umj.ac.id/index.php/semnastek.
- [21] D. Kho, "Pengertian Seven Segment Display (Layar Tujuh Segmen)," *Teknikelektronika*, vol. 0, no. Lcd, pp. 5–8, 2014.
- [23] M. U. Kholid, "Perancangan Sistem," pp. 12–25, [Online]. Available: http://www.academia.edu/7511410/Perancangan_Sistem_Menurut_Jogiyanto_H.