

Electric Power System Monitoring and Theft Detection using Power Line Communication

Minakshi Awasthi*, Amit Kumar, Deepak Kumar, Indra Jeet Pal

Gautam Buddha University, Greater Noida, Uttar Pradesh, India

*Corresponding author E-mail: minakshi.awasthi26@gmail.com

Manuscript received 30 Nov 2021; revised 3 Dec 2021; accepted 10 Jan 2022. Date of publication 10 April 2022

Abstract

Electric power theft is a serious concern in the world irrespective of being major revenue losses and developing a nation. More than one-third part of the electricity generated power is lost due to electric theft, power loss, and inefficiencies in the distribution system. Interdicted or illegal utilization of electricity has not only affected economically but also obstructs the design and modeling phases of the power system. Due to electric theft, providing wrong data input values for power system analysis and difficult to load forecasting. In this paper, an inventive Simulink model is designed to detect and monitoring of electric power theft in power system distribution networks through Power Line Communication (PLC). Electric power theft was detected with variance amendment in the amplitude of carrier signal with a narrow band. PLC technique is utilized for data communication over the power line. A narrow band power line carrier signal which has high frequency transferred in power line alongside with power frequency signal. The deviation in the amplitude of the transmitted carrier signal is monitored at the regular time- intervals and the stealing of electricity can be distinguished by the computing of distinction change within the amplitude of the carrier signal. In a normal case, the signal present fixes pattern and waveform, but in the case of power theft, the signal shows some variation and disturbance in a within waveform pattern. A pattern recognition and monitoring approach is used for direct power theft in the PLC model. The Simulink model is performed on MATLAB software to analyze the performance and efficient results that satisfy the proposed Simulink model.

Keywords: Power System Monitoring, PLC, Electric Power Theft.

1. Introduction

Electric power is one of the main keys to developing a nation to growing economies universal, but electricity theft in India has a massive result on the Indian economy. Crores of rupees every year lose in India due to electricity utilities power theft. Electricity theft is a crime According to Section 135 of the Electricity Act 2003. It occurs when someone taps electric power lines, tampering with electric meters, transformers, or through a device to hinder reading or indemnities equipment such as electric reading meters. An enormous portion of power loss occurs to power theft which imbalanced electric power forecasting. In India, grid failure (blackout) that happened on 30 July 2012 and 31 July 2012 due to the larsignificantefrequency variations between the grids and blacktookake place for two days and affected around 600 million people India. Power theft loss is reflected in the standard rate to analyze electricity by the company. So, these costs are frequently approved and scheduled to theo the customers in the outline of the privileged energy charges [1] [2] [3]. Mainly the electricity theft occurs at two places, domestic energy meter and pole side distribution line [4]. On the household energy meter side, the theft occurs via side-stepping the energy meter using a piece of wire, people simply bypass the energy meter by placing a wire before and after the meter reading unit [8]. Theft of electricity in the world is surrounded by the foremost loss of money income, ignoring being a developed or a developing country [5] [6]. The arrangement is to sense and monitor the theft of electricity using the principle of PLC. PLC acts as a transmission, automation so that allows sending data throughout electric power cables [7] [8] [9] [10] [11]. Power theft is a serious concern in distribution power systems, which causes the power quality problems like imbalance voltage, fluctuation, flicker, frequency variance, and noise [11] [12]. Non-Technical Losses (NTL) in the power distribution system are the transmission and distribution losses created from electrical theft and another illegitimate usage of electricity. The NTL covers of illegal connections, meter tampering, billing errors, etc. United States of America (USA) has NTL estimated to be about 0.5% to 3.5% of the gross annual revenue. In India, the loss of power electricity due to theft is predictable around 20% to 30% of the inclusive loss in power utility [13].



2. Literature Review

Power line carrier communication (PLCC) technology has been frequently used since 1950 by the grid stations to transmit information at high speed. Transmitting information along high-voltage lines, at high frequency are the main reason for communication in electric power for over fifty years [14] [15] [16]. The data which have information signals is composed of dissimilar sensors and then communicated on power lines thereby decreasing the preservation cost of extra wiring. In some countries, this technology has been in used to provide internet connection. In order to communicate, high-frequency line traps are used as they allow substations to communicate with each other through the power lines at the same time as they transmit electrical power. In order to separate power from messages being sent, different frequencies are used. Electrical power has a frequency of 50 Hz or 60 Hz in most places, and the communication waves use frequencies such as 150 kHz and 200 kHz [14] [17]. In the domiciliary and industries, designing of high-speed broadband communication, power stations, substation connection, and in favor of scheming appliances is utilized through PLC [18]. A filtering circuit is implemented within power frequency signals which have dispersed signals [19] [20].

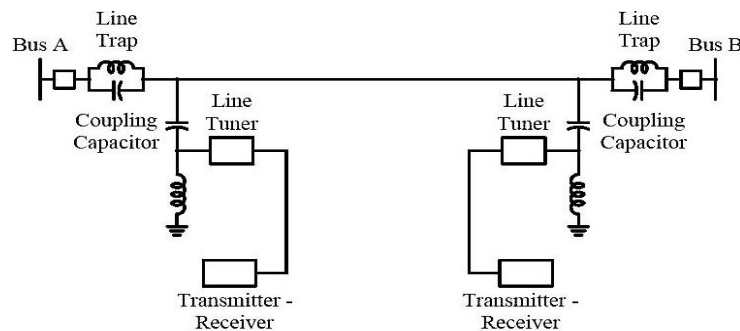

Fig 1. System Model of Power Line Communication

Line-traps and coupling capacitors are chosen in the depiction form of the PLC for the preserve of excluding the carrier signals from the power frequency signal [21]. Impedance matching can be designated by line tuner circuits which are enclosed through the carrier signal of the transmission line. Line tuner circuits are being provided for matching the impedance between the transmitted carrier signal and the transmission line [13] [22].

Line Trap or Wave Trap- A wave trap consists of a series inductance which is a shunt within a tuning capacitance. The line trap works as a high impedance for tuned frequency, however performing as a low impedance path for power frequency [17]. It is used to present a high impedance value to carrier frequencies to limit the insertion losses into the substation and to maximize the blocking attenuation at the carrier frequency. A line trap (high-frequency stopper) is a maintenance-free parallel resonant circuit, mounted inline on high-voltage (HV) AC transmission power lines to prevent the transmission of high frequency (40 kHz to 1000 kHz) carrier signals of power line communication to unwanted destinations [23]. The line-trap acts as a barrier or filter to prevent signal losses and it is also used to attenuate the shunting effects of high voltage lines [4].

Coupling Capacitor- The coupling capacitor is the device which provides a low impedance path for the carrier energy to the high voltage line, and at the same time blocks the power frequency current by being a high impedance path at those frequencies [23]. It can only perform its function of dropping line voltage across its capacitance if the low voltage end is at ground potential. Since it is desirable to connect the line tuner output to this low voltage point a device must be used to provide a high impedance path to the ground for the carrier signal and a low impedance path for the power frequency current [4]. The coupling capacitor provides a low impedance path for carrier frequencies while providing a high-impedance path for power frequencies. The coupling capacitor protects the PLCC equipment from low frequency [24]. It is desirable to have the coupling capacitor value as large as possible in order to lower the loss of carrier energy and keep the bandwidth of the coupling system as wide as possible [17] [25]. However, due to the high voltage that must be handled and the financial budget limitations, the coupling capacitor values are not as high as one might desire, the capacitance values in use range from 0.001 to .05 microfarads

Line Tuner- It is connected in series within a coupling capacitor to form a resonant circuit or carrier signal frequency high pass or band pass filter. Its function is to match the impedance of the PLC terminal with the power line in order to impress the carrier frequency over the power line [26]. In addition, it also provides isolation from power frequency and transient overvoltage protection. A line tuner provides a means of coupling a band of frequencies to the HV line with a minimum loss in power. The purpose of the line tuner in conjunction with the coupling capacitor is to provide a low impedance path for the carrier energy to the transmission line and a high impedance path for the power frequency energy. Line tuner also utilized to provide matching of impedance between the carrier coaxial cable, usually 50 to 75 ohms, and the power line which will have an impedance of 150 to 500 ohms [17] [21].

Transmitter and Receiver – Transmitter and receiver are generally mounted in a rack or cabinet in the controlling chamber and line tuner situated in the switchyard. The equipment and line tuner are associated with coaxial Fiber Optical (FO) cable. A connection is made between the coaxial cable and the line tuner mounted in the coupling capacitor's base. Thus there is a large distance between the equipment and the tuner as there is a large distance between them. Coaxial cable shields the signal from noise interference.

3. Method

OFDM modulation technique was first introduced in the 1960s and 1970s to minimization of interference between the channels which is close to each other in frequency [27].“It usages an enormous quantity of carriers, everyone carrying la little bit data rate and robust to selective fading, interfering, and multipath effects and delivehigh-graderade spectral efficiency. The use of power lines which were originally designed for AC power distribution at 50 Hz and 60 Hz, presents some technical challenges for data transmission at these frequencies

[25]. OFDM is now widely used as the most promising modulation scheme for a severe communication environment such as the PLC channel [18]. The characteristics of this channel introduce the effect of noise, attenuation, and multipath propagation which are the major challenges in implementing a PLC system. The application of OFDM in PLC enhances good performance through high spectral OFDM operation is carried out after the data is modulated using Quadrature Phase Shift Keying (QPSK) which is the input data stream. Subcarriers in the OFDM system are overlapping and orthogonal, which greatly improves the spectral efficiency necessary for a medium that has limited spectral capacity like the power line.

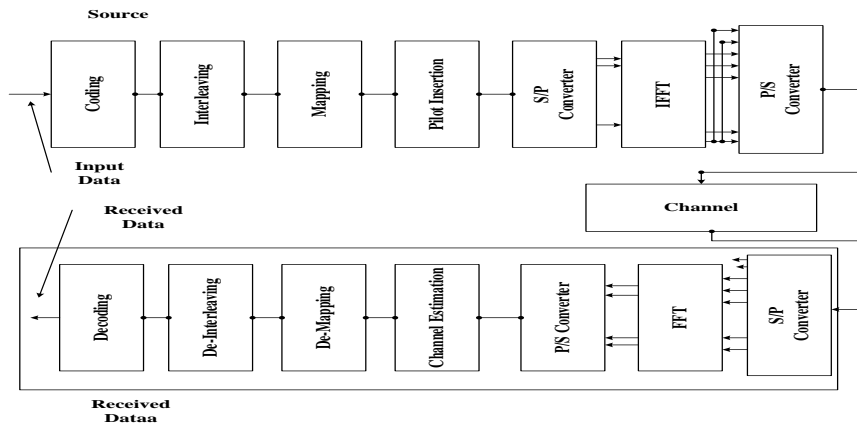

Fig 2. Basic Model of PLC with OFDM System

The testing of individual categories of modulations and data communication coding throughout the power line contains proficiency in producing representation. Fig 2 shows the QPSK, 16-QAM (Quadrature Amplitude Modulation), and 64-QAM modulation in the OFDM scheme commencing the perspective of comparing bit error rate (BER) by the established signal-to-noise ratio (SNR). To ensure suitable system performance, the complete losses of the carrier system must be low enough to provide an efficient communication path, i.e. SNR must be high.

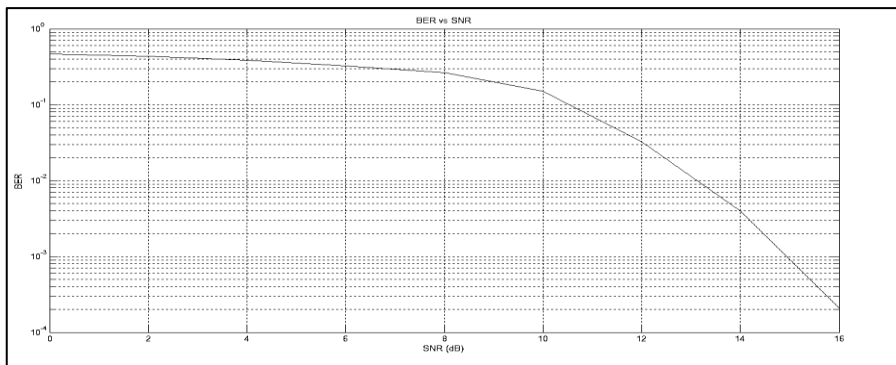

Fig 3. BER performance of QPSK-OFDM PLC System

Fig. 3 presents the relation between Bit Error Rate (BER) and Signal to Noise Ratio (SNR). BER presents the number of bits in error divisible by the total number of transmitted bits. The lower plot value is an indication of the lower BER value and better communication. Also with the increasing value of SNR, the plot moves down i.e. BER reduces, hence for better BER needed higher SNR [28]. From the graphs, it is clearly visible that the data which is transmitted through the reference channel 4, which represents an existing inhabited topology, the BER curve doesn't converge and goes straight i.e. higher BER and hence poor communication channel. Thus certainly this channel cannot be used for data transfer through it. If done so, out of total transmitted bits a large number of bits will be received in error, and definitely cannot be recovered back. BER for QPSK-OFDM is higher than BER for BPSK-OFDM, which is true because the BER of QPSK is lower than that of Binary Phase Shift Keying (BPSK). BER approach is used to moderate and decrease the effect of spontaneous or impulsive noise over the PLC network for advanced arrangements to raise data rates through alternate forward error correction coding techniques and appropriate filters.”

3. Result and Discussion

In an electric power distribution system, any variance that occurs with load causes a deviation in the usual power frequency signal at 230V, 50Hz. Additional load with the system produces a potential drop of voltage across the load. However this potential difference is temporary like that voltage sag, it is remunerated through tap-changing trans-former scheme, capacitor-bank, and Flexible Alternating Current Transmission System (FACTS) devices. FACTS devices such as Dynamic-Voltage Restorer (DVR), Unified Power Flow Conditioner (UPFC), Distribution Static Compensator (DSTATCOM), and Static Compensator (STATCOM) are used to maintain the stability, power factor, and voltage profile of the system. In PLC, a higher-order frequency signal is additional along with within ordinary or normal-power frequency signal with the help of inductive and capacitive components. The inductive nature components block the high order frequency signals and allow the passing of the low-level frequency signal then inductive impedance ($Z_L \propto \text{frequency} (f)$). Capacitive components allow passing high-frequency carrier signals and blocking lower frequency signals than $Z_L \propto 1/f$. The allocation of frequency band has intended with PLC originate commencing 3kHz to 148 kHz which contain narrow band PLC.

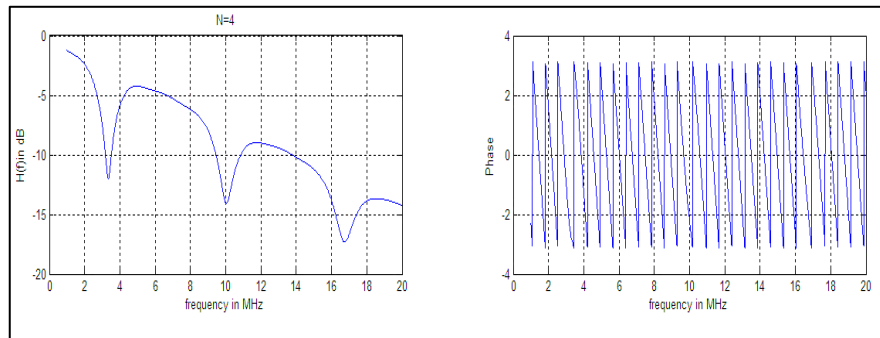

Fig 4. PLC Channel Model Gain and Phase Plot, N=4

The channel coding of the modulation utilizes the established signal-to-noise ratio on the basis of the BER principle. The second-hand types of channel coding have commenced and the modified conclusion of the density coder for maximum outstanding capability. The permanent amount of data required for a particular time modulation. The permanent data have chosen 1.105 signs.

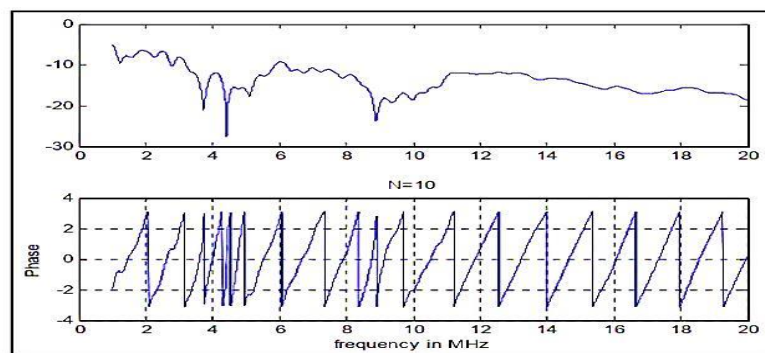

Fig.5. Multi-path Channel Model with Number of paths = 10

Different numbers of paths exist in the multipath channel, from the simulation results the number of the path is 4 and path 10 are shown in Figures 4 and 5 respectively, from the results is concluded that the notch's position does not change. However, in forwarding, increasing the number of paths from 4 to 10 represents the attenuations of notching points, and signal distortion tends to increase.

PLC Simulink model is designed with the help of MATLAB Software to study and performance of theft electricity. A combination of standard or nominal power frequency signals and high-order frequency signals are collectively transmitted over an electric distribution line through a proper channel which is a line-trap and coupling capacitors. At input, the circuit model comprises an inductor in series with a power supply at normal power frequency to block high-frequency carrier signals. Across high frequency, a coupling-capacitor is interlinked within a series resistor to protect the oscillator circuit from the power frequency supply. The resistor in series is connected in a circuit model instead of a line-tuner to pose impedance matching. In superior power networks, PLCC is used for transmitting data signals over the transmission line and also used to provide protection for transmission lines in an abnormal case. In the US, the frequency range of carrier signal is selected between 30 kHz to 200 kHz and 80-500 kHz in the UK. In India, it ranges from 3 kHz to 148.5 kHz. The frequency of the carrier signal is selected as 150 kHz to come across the standard of the Federal Communication Commission (FCC), USA [21]. FCC recognized by Communications Act- 1934

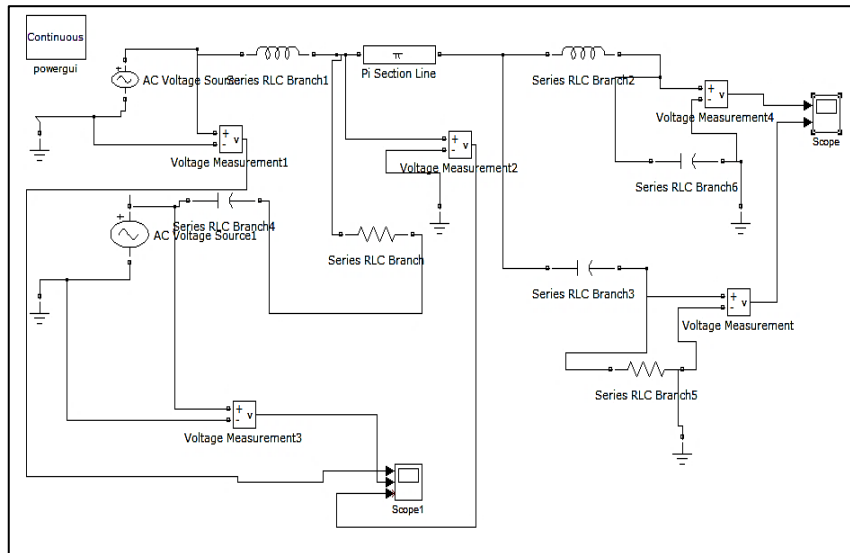

Fig 6. Simulink Model without Theft Load

As per the principle of PLC, an additional signal is added with the power frequency signal. The combined signal through the distribution line will have the amplitude of 250 V and a power frequency voltage value of 230 V is being additional within the high-frequency signal value whose amplitude is 20 V.

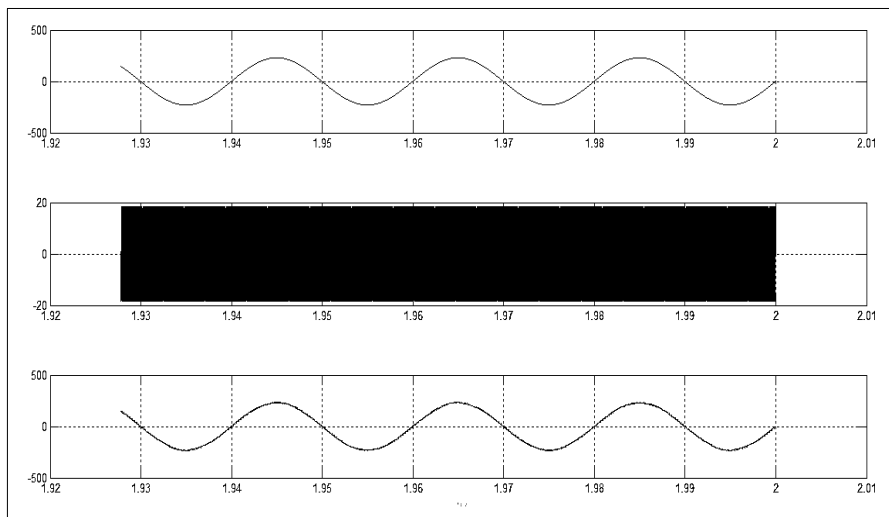

Fig 7. Simulation Output without Theft Load

Fig. 7 presents the waveform behavior without theft load. The X-axis (horizontal) presents the time in seconds and Y-axis (vertical) presents the amplitude in voltage. The waveform is sinusoidal; there is no fluctuation and sag in the case without theft load. In the power distribution system, each pole has a filtering circuit along with a detection circuit placed for the purpose of extrication the signals and monitoring the high-frequency signals respectively. The pole-based circuit will consist of Analog Low Pass Filter (ALPF) which passes the power frequency signal to the authorized consumers and Analog High Pass Filter (AHPF) which will pass the high-frequency carrier signal to the detection circuit.

In the case of electric theft, there is attenuation in both the power frequency signal and high range frequency carrier signal due to the presence of impedance in the circuit. However compensation in power frequency signal, there is no change in waveform and amplitude. In case of illegal usage of electricity or electric theft, there is no compensation for high-frequency carrier signal there will be power signal loss which produces attenuation in carrier signal because of impedance.

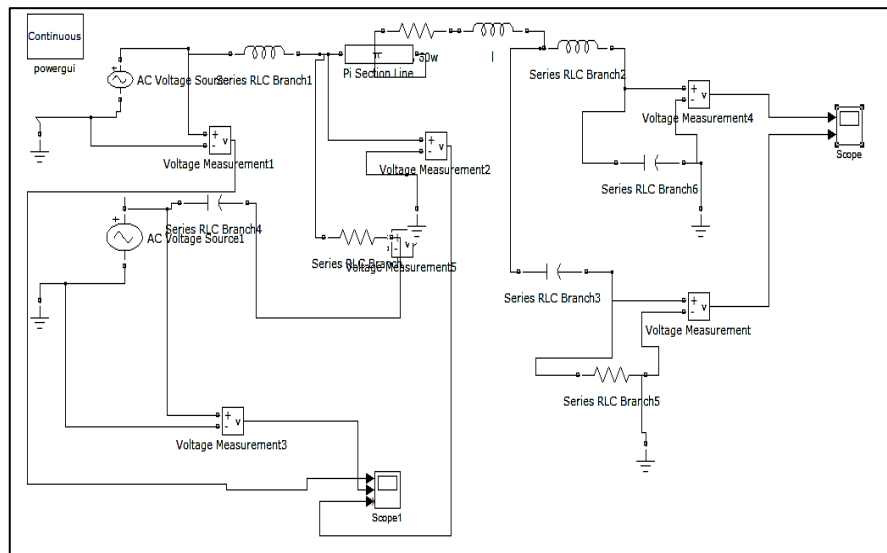

Fig 8. Simulink Model with Theft Load

RL load is deliberated for the perseverance of simulation. The load is linked in series within the transmission line with respect to the generator. For a load of Resistance $R=2\Omega$ and inductance, $L=8\text{ mH}$ are coupled in series within the power distribution line, a comparable loss occurs in high-frequency carrier signal due to the increase in the impedance surge of the circuit. The electric power theft is detected by comparison of amplitude output within reference conditions.

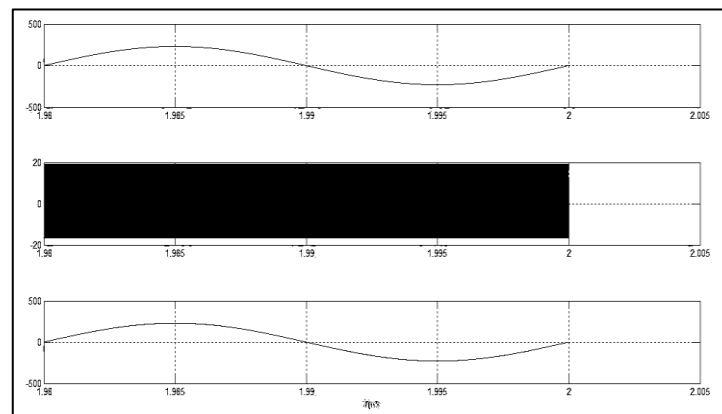

Fig 9. Simulation Output with Theft Load

There is a potential drop in the power frequency signal and in the high-frequency signal and the resistance value of theft load is high. Similar to the motor load, the theft can be detected with the help of a voltage drop in the high-frequency signal. In Fig 9, X-(horizontal) axis presents the time in the second, and the Y-(vertical) axis presents the amplitude in voltage. The frequency signal fluctuates according to the load. For such a load, the load resistance is evaluated by,

$$R = V^2 / P \Omega$$

Where, R – Resistance of the load

V – Voltage drop across the load

P – Power consumed by the load

By using the above formula, calculate the voltage, resistance and total consumed power, if the load resistance is deliberated to be identical to 2400Ω , then the electric power theft load value can be calculated. For such a theft load, the proposed scheme is applied and the simulation result is obtained.

4. Conclusion

The simulation results with theft and without theft condition has been demonstrated through PLC technique, it is effectively works for detection electric theft, shielding transmission line from incident abnormal cases, protect from power grid failure and monitoring of electricity in power system. It is more effective, precise and reliable for the power utilities with comparison to other existing system. Electric power monitoring provides peak load, load demand and energy consumption an easy way to spontaneously retrieve and evaluate power quality issues. There will be a variation in with amplitude of high frequency carrier signal because of circuit impedance, can be distinguished effectively through PLC. There is no necessity of composite electric circuit for measuring high frequency signal. The enactment of electric power theft detection scheme is cost efficient and reliable. The implementation of microcontroller, micro-chip and artificial intelligence software coding based electric theft detection devices will increase the revenue and helps to study load forecasting, new methodology and techniques to saving the electric power for future aspects.

References

- [1] A. I. Abdullateef, M. J. E. Salami, M. A. Musse, A. M. Aibinu, and M. A. Onasanya, "Electricity Theft Prediction on Low Voltage Distribution System Using Autoregressive Technique," *Int. J. Res. Eng. Technol.*, vol. 1, no. 5, 2012.
- [2] M. J. Jeffin, G. M. Madhu, A. Rao, G. Singh, and C. Vyjayanthi, "Internet of Things Enabled Power Theft Detection and Smart Meter Monitoring System," 2020, doi: 10.1109/ICCSP48568.2020.9182144.
- [3] A. V. Christopher, G. Swaminathan, M. Subramanian, and P. Thangaraj, "Distribution line monitoring system for the detection of power theft using power line communication," 2014, doi: 10.1109/CENCON.2014.6967476.
- [4] R. J. Hamidi, S. H. Hosseinian, S. H. H. Sadeghi, and Z. Qu, "A Novel Approach to Utilize PLC to Detect Corroded and Eroded Segments of Power Transmission Lines," *IEEE Trans. Power Deliv.*, vol. 30, no. 2, 2015, doi: 10.1109/TPWRD.2014.2326167.
- [5] A. Kumar, D. Kumar, and A. Yadav, "Power quality improvement of power distribution system under symmetrical and unsymmetrical faults using D-STATCOM," in *Lecture Notes in Electrical Engineering*, 2018, vol. 508, doi: 10.1007/978-981-13-0662-4_10.
- [6] D. V. Tien, R. Gono, and Z. Leonowicz, "A multifunctional dynamic voltage restorer for power quality improvement," *Energies*, vol. 11, no. 6, 2018, doi: 10.3390/en11061351.
- [7] A. Behera and S. Mohanty, "Power quality improvement of a 25 KV distribution system under 3 phase fault using UPQC," in *International Conference on Technologies for Smart City Energy Security and Power: Smart Solutions for Smart Cities, ICSESP 2018 - Proceedings*, 2018, vol. 2018-January, doi: 10.1109/ICSESP.2018.8376677.
- [8] K. K. Ali, M. Talei, A. Siadatan, and S. M. H. Rad, "Power quality improvement using novel dynamic voltage restorer based on power electronic transformer," in *2017 IEEE Electrical Power and Energy Conference, EPEC 2017*, 2018, vol. 2017-October, doi: 10.1109/EPEC.2017.8286166.
- [9] R. Siva, P. Janaki, and M. Mangaraj, "Comparison of Power Quality Improvement between 3P2L VSI and Cascaded H-Bridge 3L Inverter Based Dual DSTATCOM," 2020, doi: 10.1109/CISPSS49931.2020.9212211.
- [10] V. Wineka Nirmala, D. Harjadi, and R. Awaluddin, "Sales Forecasting by Using Exponential Smoothing Method and Trend Method to Optimize Product Sales in PT. Zamrud Bumi Indonesia During the Covid-19 Pandemic," *Int. J. Eng. Sci. Inf. Technol.*, vol. 1, no. 4, 2021, doi: 10.52088/ijesty.v1i4.169.
- [11] V. A. Shpenst, "Complex simulation model of functioning mine telecommunication system using Power Line Communication technology," in *Journal of Physics: Conference Series*, 2021, vol. 1753, no. 1, doi: 10.1088/1742-6596/1753/1/012054.
- [12] A. Kumar, N. S. Pal, and M. A. Ansari, "Mitigation of voltage sag/swell and harmonics using self-supported DVR," 2017, doi: 10.1109/ICPEICES.2016.7853707.
- [13] M. Malleswarao, M. Balasubba Reddy, and S. Meera Shareef, "Reactive Power Compensation And Harmonics Mitigation Using Multi Level Inverter Based D- Statcom With Flc Controller," *Int. J. Adv. Sci. Technol. Eng. Manag. Sci.*, vol. 1, no. 3, 2015.
- [14] Anon, "SUMMARY OF AN IEEE GUIDE FOR POWER-LINE CARRIER APPLICATIONS.," *Proc. Annu. Reliab. Maintainab. Symp.*, 1980.
- [15] S. K. Bhagat, A. N. Yadav, V. Sharma, and N. P. Pathak, "Design, analysis and simulation of hybrid integrated NRD guide based QPSK modulator for LMDS applications at 28GHz," 2013, doi: 10.1109/NCC.2013.6487968.
- [16] R. Amudhevali and T. Sivakumar, "IoT Based Smart Energy Metering System for Monitoring the Domestic Load Using PLC and SCADA," *IOP Conf. Ser. Mater. Sci. Eng.*, vol. 1055, no. 1, 2021, doi: 10.1088/1757-899x/1055/1/012154.
- [17] Y. Wang, S. Wei, F. Yin, Y. Yang, L. Tan, and W. Cao, "Review on key technology of de-icing robot running on overhead transmission line," *Jixie Gongcheng Xuebao/Journal Mech. Eng.*, vol. 47, no. 23, 2011, doi: 10.3901/JME.2011.23.030.
- [18] M. P. Sanders, "A reliable power-line carrier-based relay system: Avoiding mistakes that cause PLC systems to misoperate or fail to operate," 2012, doi: 10.1109/CPRE.2012.6201240.
- [19] V. Dadi and S. Peravali, "Optimization of light-dependent resistor sensor for the application of solar energy tracking system," *SN Appl. Sci.*, vol. 2, no. 9, 2020, doi: 10.1007/s42452-020-03293-x.
- [20] A. Hatem Tameem Alfarra, B. Amani Attia, and C. S. M. El Safty, "Nontechnical loss detection for metered customers in alexandria electricity distribution company using support vector machine," *Renew. Energy Power Qual. J.*, vol. 1, no. 16, 2018, doi: 10.24084/repqj16.353.
- [21] W. Chen *et al.*, "AI assisted PHY in future wireless systems: Recent developments and challenges," *China Commun.*, vol. 18, no. 5, 2021, doi: 10.23919/JCC.2021.05.019.
- [22] S. Ghosh, "Performance Evaluation of Different Coding and Modulation Scheme in LTE Using Different Bandwidth and Correlation Levels," *Wirel. Pers. Commun.*, vol. 86, no. 2, 2016, doi: 10.1007/s11277-015-2945-6.
- [23] B. Mork, D. Ishchenko, X. Wang, A. Yerrabelli, R. Quest, and C. Kinne, "Power Line Carrier Communications System Modeling," *Int. Conf. Power Syst. Transients*, 2005.
- [24] S. Samal, P. K. Hota, and P. K. Barik, "Harmonics mitigation by using shunt active power filter under different load condition," 2017, doi: 10.1109/SCOPE.2016.7955598.
- [25] A. Aswin, R. Chidambaram, S. B. Kavin Darshan, N. Abinav Soorya, and S. Senthilmurugan, "Design of smart energy meter with power theft detection and a novel of billing payment," *Int. J. Recent Technol. Eng.*, vol. 7, no. 6, 2019.
- [26] C. Applications, *IEEE Std 643™-2004: IEEE Guide for Power-Line Carrier Applications*. 2005.
- [27] J. Nagi, K. S. Yap, F. Nagi, S. K. Tiong, S. P. Koh, and S. K. Ahmed, "NTL detection of electricity theft and abnormalities for large power consumers in TNB malaysia," 2010, doi: 10.1109/SCORED.2010.5704002.
- [28] Z. Rasin and M. R. Abdullah, "Water Quality Monitoring System Using Zigbee Based Wireless Sensor Network," *Int. J. Eng. Technol.*, 2009.